

AN EASY-TO-BUILD, HIGH-PERFORMANCE PASSIVE CW FILTER

Modern commercial receivers for amateur radio applications have featured CW filters with digital signal processing (DSP) circuits. These DSP filters provide exceptional audio selectivity with the added advantages of letting the user change the filter's center frequency and bandwidth. Yet in spite of these improvements, many hams are dissatisfied with DSP filters due to increased distortion of the CW signal and the presence of a constant low-level, wide-band noise at the audio output. One way to avoid this distortion and noise is to switch to a selective passive filter that generates no noise! Although the center frequency and bandwidth of the passive filter is fixed and cannot be changed, this is not a serious problem once a center frequency preferred by the user is chosen. The bandwidth can be made narrow enough for good selectivity with no ringing that frequently occurs when the bandwidth is too narrow. This passive CW filter project was designed, built and refined over many years by ARRL Technical Advisor Edward E. Wetherhold, W3NQN.

The effectiveness of an easy-to-build, high-performance passive CW filter in providing distortion-free and noise-free CW reception—when compared with several commercial amateur receivers using DSP filtering—was experienced by Steve Root, KØSR. He reported that when he replaced his DSP filter with the passive CW filter that he assembled, he had the impression that the signals in the filter passband were amplified. In reality, the noise floor appeared to drop one or two dB. When attempting to hear low-level DX CW signals, Steve now prefers the passive CW filter over DSP filters.¹ The CW filter assembled and used by KØSR is the passive five-resonator CW filter that has been widely published in many Handbooks and magazines since 1980 (see references 2-11 at the end of this text).

If you want to build the high-performance passive five-resonator CW filter and experience no-distortion and no-noise CW reception, this article will show you how.

This inductor-capacitor CW filter uses one stack of 85-mH inductors and two modified separate inductors in a five-resonator circuit

that is easy to assemble, gives high performance and is low cost. Although these inductors have been referred to as “88 mH” over the past 25 years, their actual value is closer to 85 mH, and for that reason the designs presented in this article are based on an inductor value of 85 mH.

Five band-pass filter designs for center frequencies between 546 Hz and 800 Hz are listed in **Table 12.25**. Select the center frequency that matches your transceiver sidetone frequency. If you are using a direct conversion receiver or an old receiver with a BFO, you may select any of the designs having a center frequency that you find easy on your ears. The author can provide a kit of parts with detailed instructions for assembling this filter at a nominal cost. For contact information, see the end of this text.

The actual 3-dB bandwidth of the filters is between 250 and 270 Hz depending on the center frequency. This bandwidth is narrow enough to give good selectivity, and yet broad enough for easy tuning with no ringing. Five high-Q resonators provide good skirt selectivity that is adequate for interference-free CW reception. Simple construction, low cost and good performance make this filter an ideal first project for anyone interested in putting together a useful station accessory, provided you operate CW mode of course!

DESIGNS AND INTERFACING

Fig 12.89 shows the filter schematic diagram. Component values are given in Table 12.25 for five center-frequency designs. All designs are to be terminated in an impedance between 200 and 230 Ω and standard commercial 8 Ω to 200 Ω audio transformers are used to match the filter input and output to the 8 Ω audio output jack on your receiver—and to an 8 Ω headset. Details are discussed a bit later in this text to interface using headphones with other than 8 Ω impedances that are now quite common.

CONSTRUCTION

The encircled numbers in Fig 12.89 indicate the filter circuit nodes for reference. **Fig 12.90A** shows the L2 and L4 inductor lead connections for the 546-Hz design where no turns need to be removed; the two inductors are used in their original condition. For all other designs, turns need to be removed from each of the windings. The number of turns requiring removal from the L2 and L4 windings is listed in Table 12.25.

Fig 12.90B shows a pictorial of the filter assembly and the connections between the capacitors and the 85-mH stack terminals. Inductors L1, L3 and L5 are contained within the inductor stack and are interconnected using the terminal lugs on the stack as shown in

Table 12.25

CW Filter Using One 85-mH Inductor Stack and Two Modified 85-mH Inductors

Center Freq. (Hz)	546	600	700	750	800
C1, C5 (nF)	1000	828	608	530	466
C2, C4 (μ F)	1.0	1.0	1.0	1.0	1.0
C3 (nF)	333	276	202.7	176.5	155
L2, L4 (mH)	85	70.36	51.69	45.0	39.6
Remove Turns*	None	66	160	200	232

*The total number of turns removed, split equally from each of the two windings of L2. Do the same also for L4. (For example, for a 700-Hz center frequency, remove 80 turns from each of the two windings of L2, for a total of 160 turns removed from L2. Repeat exactly for L4.)

For all designs: L1, L5 = 85 mH; L3 = 255 mH (three 85 mH inductors). Although the surplus inductors are commonly considered to be 88 mH, the actual value is closer to 85 mH. For this reason, all designs are based on the 85-mH value. L2 and L4 have white cores, Magnetic Part No. 55347, OD Max = 24.3mm, ID Min = 13.77mm, HT = 9.70mm; μ = 200, AL = 169 mH/1000T \pm 8%. The calculated 3-dB BW is 285 Hz and is the same for all designs; however, the actual bandwidth is 5 to 10-percent narrower depending on the inductor Q at the edges of the filter passband.

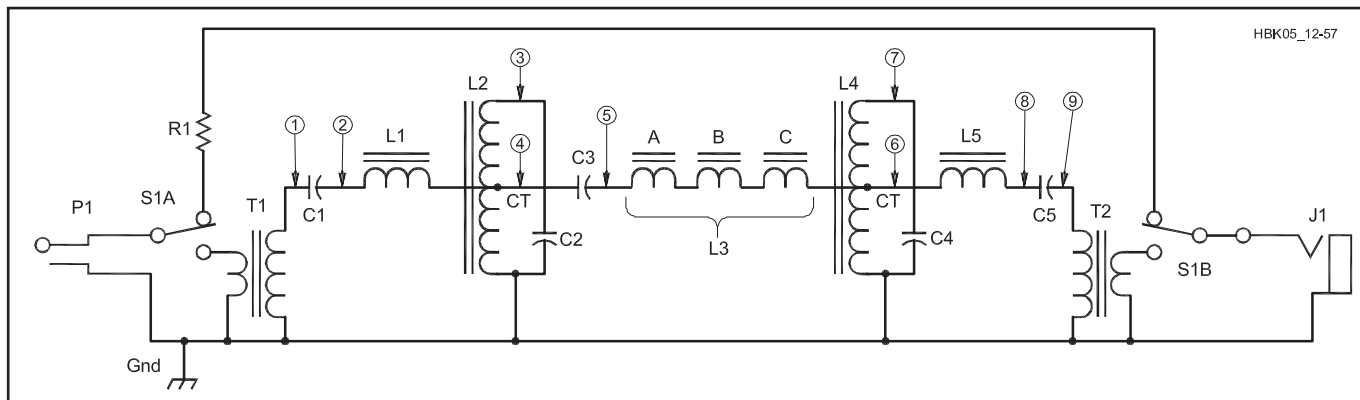

HBK05_12-57

Fig 12.89 — Schematic diagram of the five-resonator CW filter. See Table 12.25 for capacitor and inductor values to build a filter with a center frequency of 546, 600, 700, 750 or 800 Hz.

P1 — Phone plug to match your receiver audio output jack.
J1 — Phone jack to match your headphone.

R1 — 6.8 to 50 Ω, ¼-W, 10% resistor (see text).
S1 — DPDT switch.
T1, T2 — 200 to 8-Ω impedance-matching transformers, 0.4-W, Miniature Core

Type EI-24, Mouser No. 42TU200.
Note: The circled numbers identify the circuit nodes corresponding to the same nodes labeled in the pictorial diagram in Fig 12.90.

the pictorial diagram. The encircled numbers show the circuit nodes corresponding to those in Fig 12.89.

After the correct number of turns are removed from L2 and L4, the leads are gently scraped until you see copper and then the start lead (with sleeving) of one winding is connected to the finish lead of the other winding to make the center tap. The center tap lead and the other start and finish leads of L2 and L4 are connected as indicated in

Fig 12.90B. L2 and L4 are fastened to opposite ends of the stack with clear silicone sealant that is available in a small tube at low cost from your local hardware store. Use the silicone sealant to fasten C2 and C4 to the side of the stack. The capacitor leads of C1, C3 and C5 are adequate to support the capacitors when their leads are soldered to the stack terminals. Fig 12.90C is a photo of the assembled filter installed in a Jameco plastic box. Transformers T1 and T2 are

secured to the bottom of the plastic box with more silicone sealant and are placed on opposite sides of the DPDT switch. See the photograph for the placement of the phone jack and plug.

After the stack and capacitor wiring is completed, the correctness of the wiring is checked before installing the stack in the box. To do this, check the measured node-to-node resistances of the filter with the values listed in Table 12.26.

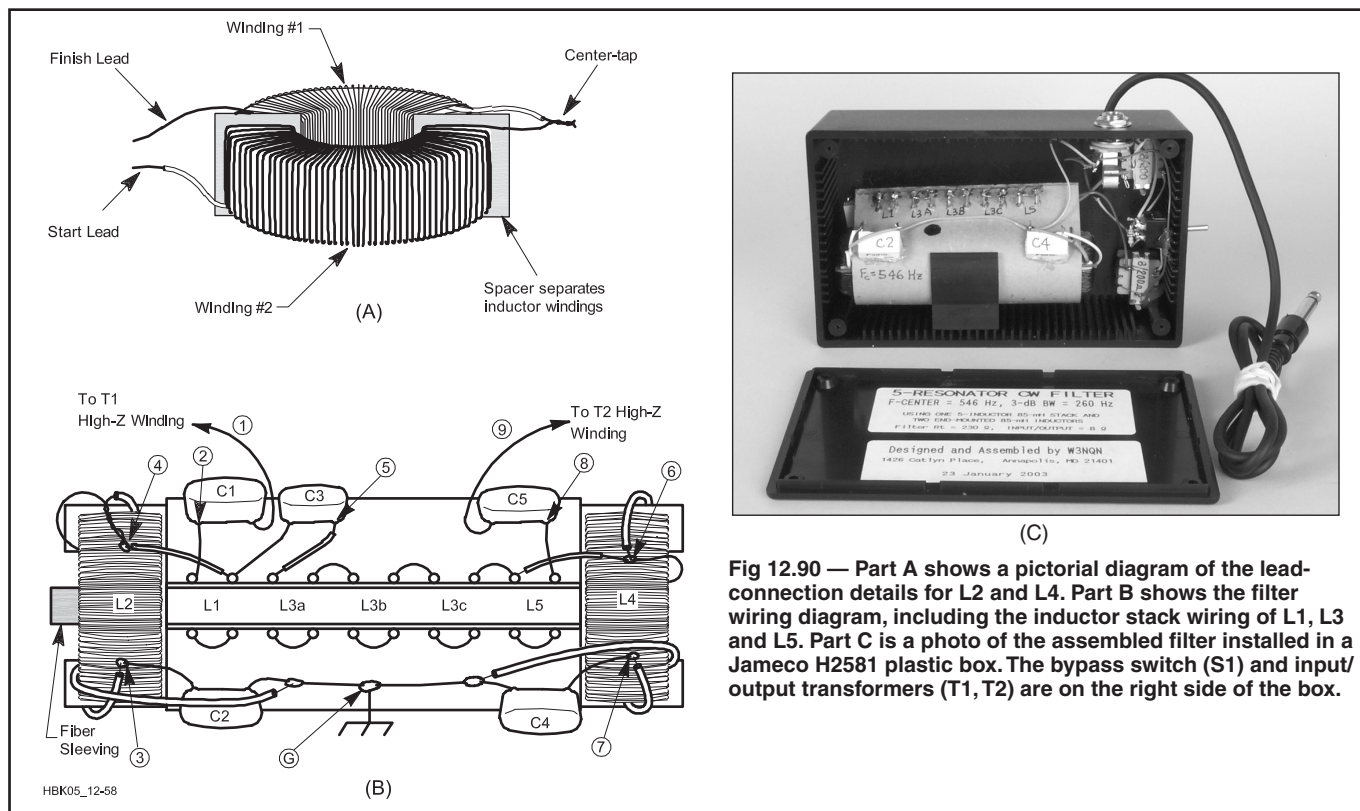

Fig 12.90 — Part A shows a pictorial diagram of the lead-connection details for L2 and L4. Part B shows the filter wiring diagram, including the inductor stack wiring of L1, L3 and L5. Part C is a photo of the assembled filter installed in a Jameco H2581 plastic box. The bypass switch (S1) and input/output transformers (T1, T2) are on the right side of the box.

Table 12.26
Node-to-Node Resistances for the 546-Hz CW Filter

From Node	To Node	Component Designation	Resistance (ohms ±20%)
1	GND	T1 hi-Z winding	12
2	GND	L1 + 1/2(L2)	12
3	GND	L2	8
4	GND	1/2(L2)	4
5	GND	L3 + 1/2(L4)	28
6	GND	1/2(L4)	4
7	GND	L4	8
8	GND	L5 + 1/2(L4)	12
9	GND	T2 hi-Z winding	12
2	4	L1	8
5	6	L3	24
6	8	L5	8
2	3	L1 + 1/2(L2)	12
8	7	L5 + 1/2(L4)	12

Notes

1. See Figs 12.89 and 12.90 for the filter node locations.
2. Check your wiring using the resistance values in this table. If there is a significant difference between your measured values and the table values, you have a wiring error that must be corrected!
3. The resistances of L2 and L4 in the four other filters will be somewhat less than the 546-Hz values. For accurate measurements, use a high-quality digital ohmmeter.

INTERFACING TO SOURCE AND LOAD

The T1 and T2 transformers match the filter to the receiver low-impedance audio output and to an 8 Ω headset or speaker. If your headset impedance is greater than 200 Ω, omit T2 and connect a 1/2-watt resistor from node 9 (C5 output lead) to ground. Choose

the resistor so the parallel combination of the headset impedance and the resistor gives the correct filter termination impedance (within about 10% of 230 Ω).

PERFORMANCE

The measured 30-dB and 3-dB bandwidths of the 750-Hz filter are about 567 and 271

Hz, respectively. The 30/3-dB shape factor is 2.09. Use this factor to compare the selectivity performance of this filter with others. **Fig 12.91** shows the measured relative attenuation responses of the 546-Hz and 750-Hz filters. These responses were measured in a 200-Ω system without the transformers. All attenuation levels were measured relative to a 0 dB attenuation level at the filter center frequency.

The measured insertion loss of these passive filters with transformers is slightly less than 3 dB and this is typical of filters of this type. This small loss is compensated by slightly increasing the receiver audio gain.

R1 is selected to maintain a relatively constant audio level when the filter is switched in or out of the circuit. The correct value of R1 for your audio system should be determined by experiment and probably will be between 6.8 and 50 Ω. Start with a short circuit across the S1A and B terminals and gradually increase the resistance until the audio level appears to be the same with the filter in or out of the circuit.

Thousands of hams have constructed this five-resonator filter, and many have commented on its ease of assembly, excellent performance and lack of hiss and ringing!

ORDERING PARTS/CONTACTING THE AUTHOR

The author can provide a kit of parts with detailed instructions for assembling this filter at a nominal cost. The kit includes an inductor stack and two inductors, a pre-punched plastic box with a plastic mounting clip for the inductor stack, five matched capacitors, two transformers, a phone plug and jack and a miniature DPDT switch. Write to Ed Wetherhold, W3NQN, 1426 Catlyn Place, Annapolis, MD 21401-4208 for details about parts and prices. Be sure to include a self-addressed, stamped 9.5 × 4-inch envelope with your request.

Notes

- ¹Private correspondence from Steve Root, K0SR.
- ²R. Schetgen, Ed., 1994 *ARRL Handbook*, pp 28.1-28.2 (Simple High-Performance CW Filter)
- ³W. Orr, Ed., *Radio Handbook*, 23rd edition, Howard W. Sams & Co., 1987, pp 13.4-13.6 (1-Stack CW Filter).
- ⁴Wetherhold, "Modern Design of a CW Filter using 88- and 44-mH Surplus Inductors," *QST*, Dec 1980, pp 14-19 and *Feedback*, *QST*, Jan 1981, p 43.
- ⁵Wetherhold, "High-Performance CW Filter," *Ham Radio*, Apr 1981, pp 18-25.
- ⁶Wetherhold, "CW and SSB Audio Filters Using 88-mH Inductors," *QEX*, Dec 1988, pp 3-10.
- ⁷Wetherhold, "A CW Filter for the Radio Amateur Newcomer," *Radio Communication* (Radio Society of Great Britain), Jan 1985, pp 26-31.

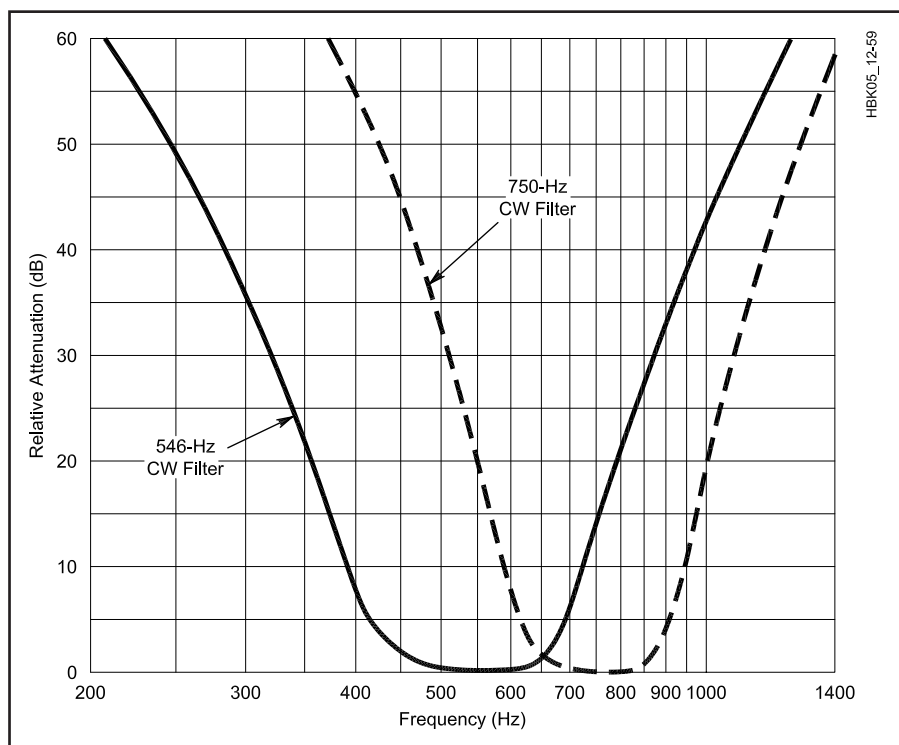

Fig 12.91 — Measured attenuation responses of the 546- and 750-Hz filters. The responses are plotted relative to the zero dB attenuation levels at the center frequencies of the filters. The other filter response curves are similar, but centered at their design frequency.